

Angle Type Special Thermometer

Model No. SS-4071~3 Series

DAEJIN



SS-4071~3

Summary

This instrument is designed to adjust the measuring angle as you want to. Therefore, you can change the location as your own discretion and measure it.

Safety Management

- Do not give impact during transportation, installation, and usage.
- Be sure to install a protecting device where exist vibration.
- Avoid places where exist a lot of steam and poisonous gas.

Purpose of Use

- A place where decoding direction of indication requires changes by own discretion.
- Various boilers
- Petrochemistry plant, food processing, etc

Production Specification

- ▶ Diameter
 - 100mm, 125mm, 150mm
- ▶ Accuracy
 - $\pm 1.0\%$ of Full Scale
 - $\pm 2.0\%$ of Full Scale
- ▶ Scale Range
 - $-30^{\circ}\text{C} \sim 650^{\circ}\text{C}$
- ▶ Common Temperature
 - 75% of Full Scale

Product Specification

- | | | |
|--|--|---|
| + Case <ul style="list-style-type: none">· STS 304 | + Window <ul style="list-style-type: none">· General glass· Tempered safety glass· Laminated safety glass | + Pointer <ul style="list-style-type: none">· Aluminum· Black coating |
| + Cover <ul style="list-style-type: none">· STS 304· Slip-on-Fit | + Type <ul style="list-style-type: none">· T-Type | + Stem <ul style="list-style-type: none">· STS 304, STS 316· Out Dia. : $\varnothing 6.4, \varnothing 8, \varnothing 10, \varnothing 12$ |
| + Connection <ul style="list-style-type: none">· STS 304· PF, PT, NPT $\leftrightarrow 1/2, 1/4, 1$ | + Dial <ul style="list-style-type: none">· Aluminum· Color of white· Black gradation and characters | + Well <ul style="list-style-type: none">· STS 304, STS 316· Titanium, Monel, Hastelloy· Teflon Lining, Glass Lining |

Pressure Gauge

Differential Pressure Gauge & Switch

Accessories of Pressure Gauge

Thermometer & Thermometer Switch

Thermocouple & R.T.D

Thermowell

Transmitter

Indicator etc.

Technical data

Model No. | SS-4071~3 Angle Type (Direct Type)

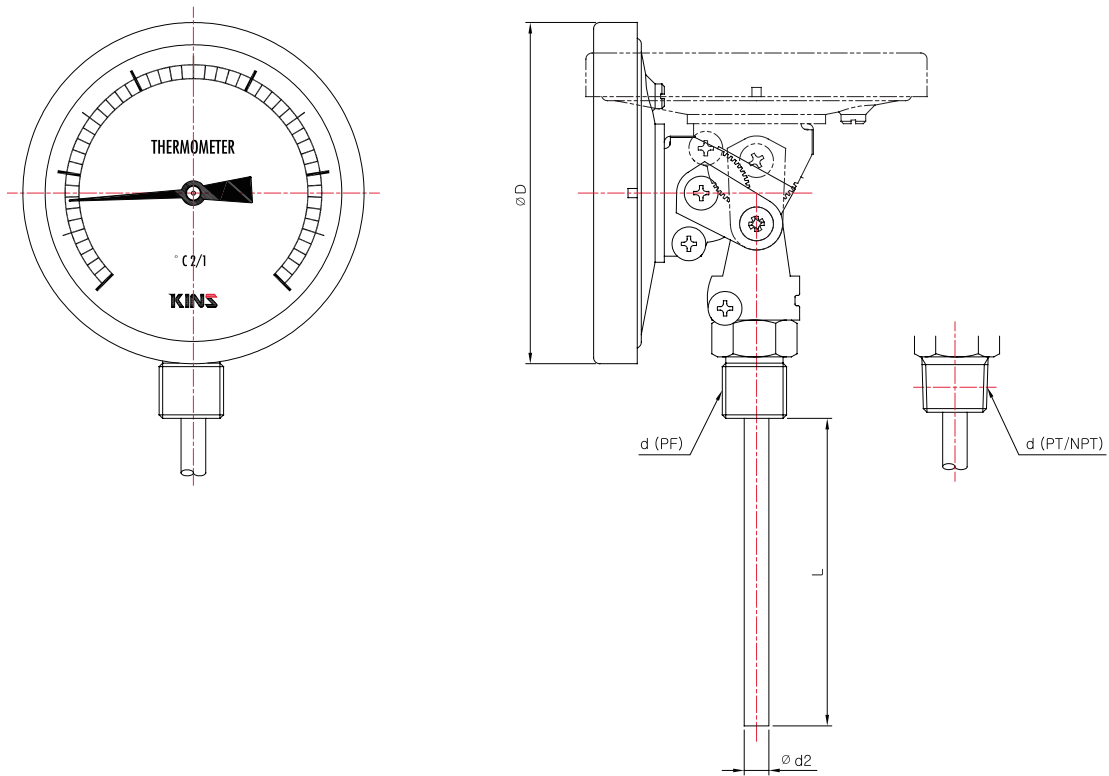

Dimensions (mm)

Model No.	ØD	Con'n (d)	Ød2	Range	Minimum Graduation	Length Of Bulb "L"		
						Minimum Insertion Length		
						Ød2 = 6.4	Ød2 = 8.0	Max.
SS-4071	110.5	PF 1/2 NPT & PT 1/2	6.4	-20 ~ 80	2	50	50	1000
				-20 ~ 100	2	45	45	
				0 ~ 50	1	75	75	
				0 ~ 80	2	60	60	
SS-4072	127.5	PF 3/4 NPT & PT 3/4	8.0	0 ~ 100	2	50	50	
				0 ~ 120	2	45	45	
				0 ~ 150	2	50	50	
				0 ~ 200	5	30	30	
SS-4073	173.0	PF 1 NPT & PT 1	8.0	0 ~ 250	5	75	75	
				0 ~ 300	5	60	60	
				0 ~ 350	5	50	50	
				0 ~ 400	10	45	45	
				0 ~ 500	10	40	40	

*()The measurement in the blanket is approximate.

Pressure Gauge

Differential Pressure Gauge & Switch

Accessories of Pressure Gauge

Thermometer & Thermometer Switch

Thermocouple & R.T.D

Thermowell

Transmitter

Indicator etc.

Technical data