

Differential Pressure Gauge (with Contact)

Model No. **SS-3301 Series**

DAEJIN



SS-3301

[The utility model registration] 20-0435022

Summary

This gauge has L (low pressure side) and H (high pressure side) in pressure access port. By indicating the differential of pressure (differential pressure) of 2 places, it is able to measure the differential pressure and by using that, able to measure liquid level and flux too.

Safety Management

- Be sure to install a protecting device where exist abrupt change of pressure, vibration and pulsation.
- Do not give impact during the transportation, installation and usage.
- Be sure to install pressure gauge to be horizontal and vertical.
 - ※ - Caution: If internal pressure on only one side of accessing port is put, it might get damage.
 - Must use 3-WAY VALVE

Purpose of Use

- Measure the influx of pipe line using orifice as a differential pressure type flow meter
- Measure sealed tank's liquid level as a differential pressure liquid level meter.
- Application line of potential difference of pressure, etc

Production Specification

- ▶ Diameter
 - 100, 150mm
- ▶ Accuracy
 - ±1.5% of Full Scale
- ▶ Scale Range
 - 5 ~ 50 kPa, 0 ~ 1 MPa
- ▶ Working Pressure
 - Static pressure : 75% of Full Scale
 - Fluctuating pressure : 60% of Full Scale
- ▶ Working Temperature
 - Ambient : - 20 ~ 80 °C
 - Fluid : - 20 ~ 80 °C
- ▶ Degree of Protection
 - IP65

Product Specification

- | | | |
|--|--|--|
| <ul style="list-style-type: none"> + Case <ul style="list-style-type: none"> · STS 304 + Cover <ul style="list-style-type: none"> · STS 304 + Connection <ul style="list-style-type: none"> · STS 316 · PT ↔ 1/4(Female) + Window <ul style="list-style-type: none"> · Poly-carbonate | <ul style="list-style-type: none"> + Pointer <ul style="list-style-type: none"> · Aluminum · Black coating + Dial <ul style="list-style-type: none"> · Aluminum · White coating · Black (MPa), red (bar) gradations and characters + Bellows(Element) <ul style="list-style-type: none"> · STS304, STS316 + Movement <ul style="list-style-type: none"> · STS 304 | <ul style="list-style-type: none"> + Connecting method <ul style="list-style-type: none"> · U-Bolt for 2B Pipe + Base Pressure <ul style="list-style-type: none"> · 5 MPa + Contact rating <ul style="list-style-type: none"> · AC 125V 0.5A / 250V 0.25A · DC 24V 0.25A + Option <ul style="list-style-type: none"> · 3-Way or 5-Way Manifold valve · Accessories |
|--|--|--|

Pressure Gauge

Differential Pressure Gauge & Switch

Accessories of Pressure Gauge

Thermometer & Thermometer Switch

Thermocouple & RTD

Thermowell

Transmitter

Indicator etc.

Technical data

Differential Pressure Gauge (with Contact)

Model No. **SS-3301 Series**

Model No. | SS-3301 (100mm) Bracket For 2B Pipe Type

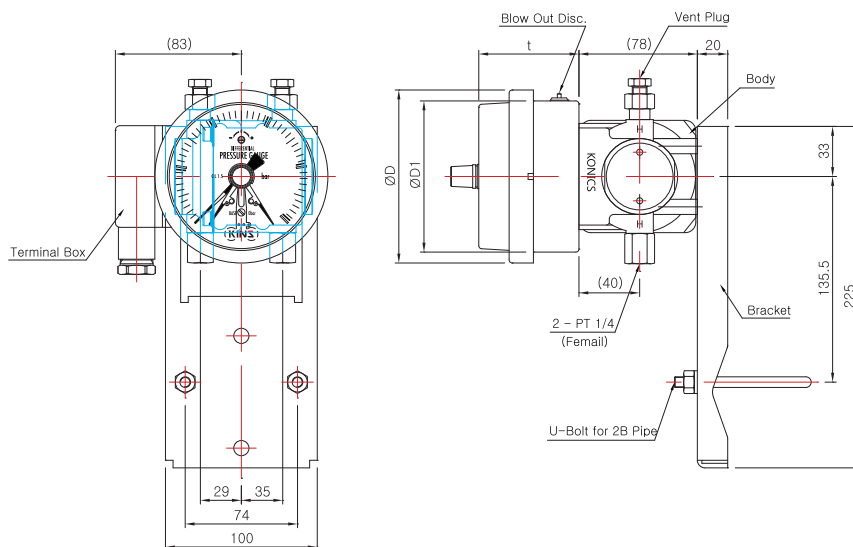

Model No. | SS-3301 (150mm) Bracket For 2B Pipe Type

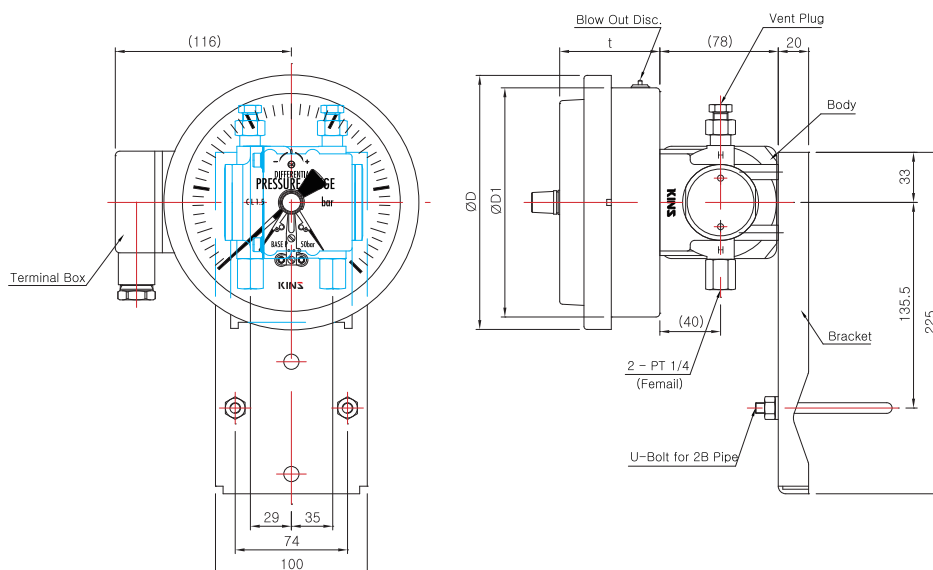

Dimensions (mm)

Model No.	Con'n (d)	ØD	ØD1	t
SS-3301-100	PT 1/4 (Femal)	114	100	(66)
SS-3301-150		168	152	(66)

*()The measurement in the blanket is approximate.

Pressure Gauge

Differential
Pressure Gauge &
Switch

Accessories of
Pressure Gauge

Thermometer &
Thermometer Switch

Thermocouple
& R.T.D

Thermowell

Transmitter

Indicator etc.

Technical data