

Level Pressure Gauge

Model No. **SS-3100 Series**

DAEJIN



SS-3100

Summary

This gauge has a chamber and has high accuracy and durability. It is easy to be attached and that's the difference with other level gauges.

Safety Management

- Do not give impact during the transportation, installation and usage.
- Be sure to install pressure gauge to be horizontal and vertical.

Purpose of Use

- Chemistry plant, ships, fuel tank with bulk storage
- Use when measuring level of liquid.

Production Specification

- ▶ **Diameter**
 - 150 mm
- ▶ **Accuracy**
 - $\pm 1.5\%$ of Full Scale
- ▶ **Scale Range**
 - Depth of tank : 1 ~ 50(M)
- ▶ **Working Pressure**
 - Static pressure : 75% of Full Scale
 - Fluctuating pressure : 60% of Full Scale
- ▶ **Working Temperature**
 - Ambient : $-20 \sim 70$ °C
 - Fluid : $-20 \sim 120$ °C

Product Specification

+ Case · STS 304	+ Type · Bracket	+ Element · STS 304, STS 316
+ Cover · STS 304 · Slip-on-Fit	+ Pointer · Aluminum · Black coating	+ Movement · Brass
+ Connection · Flange (See the drawing)	+ Dial · Aluminum · White color coating · Black gradation and characters	+ CaPillary Tube · STS304 · Max. 10M
+ Window · Tempered safety glass		+ Option

Pressure Gauge

Differential Pressure Gauge & Switch

Accessories of Pressure Gauge

Thermometer & Thermometer Switch

Thermocouple & R.T.D

Thermowell

Transmitter

Indicator etc.

Technical data

Level Pressure Gauge

Model No. **SS-3100 Series**

Model No. | **SS-3100 (150mm)**

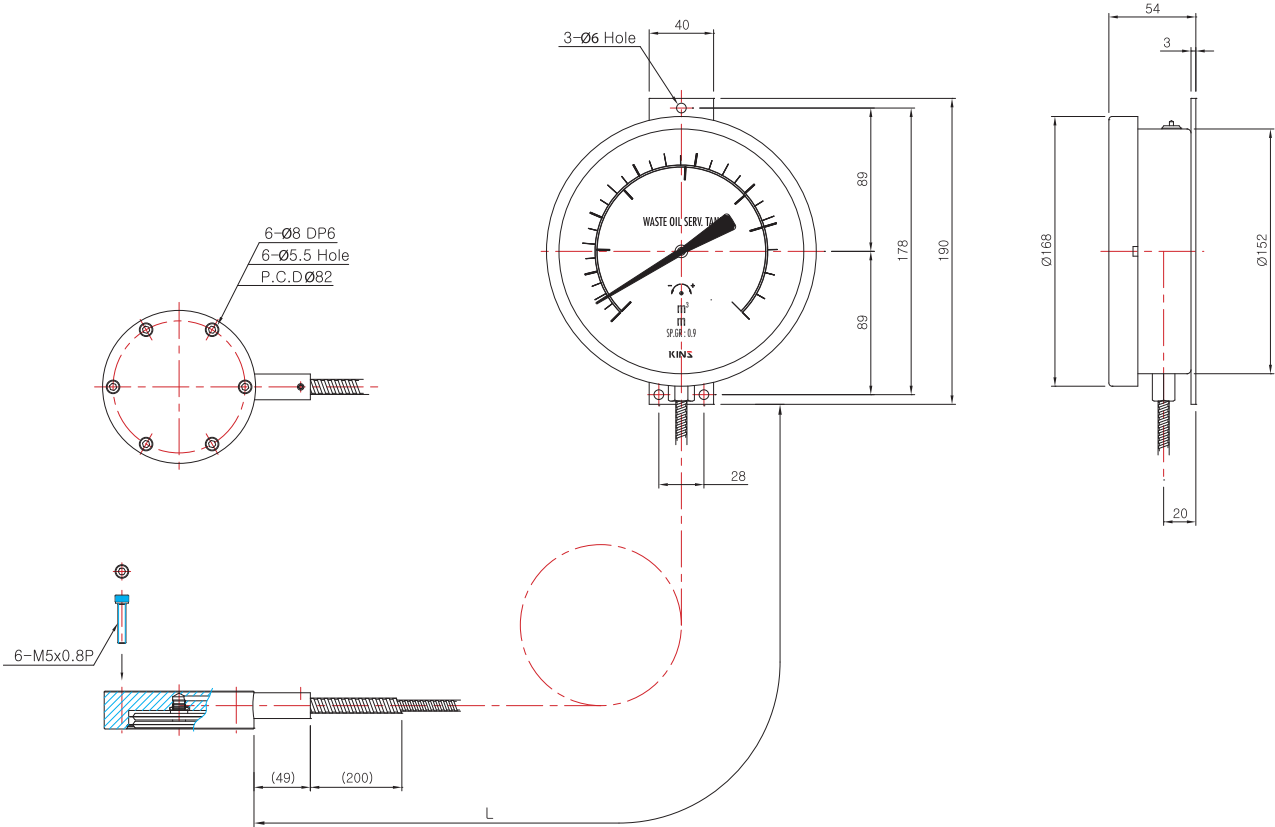

Pressure Gauge

Differential Pressure Gauge & Switch

Accessories of Pressure Gauge

Thermometer & Thermometer Switch

Thermocouple & R.T.D

Thermowell

Transmitter

Indicator etc.

Technical data