

Liquid Filled Pressure Gauge

Model No. **SS-3075/8 Series**

DAEQIN



SS-3075



SS-3078

Summary

This gauge is proper for measuring the pressure in place where mechanical vibration and pulsation are heavy because its interior devices are precipitated in silicon liquid and by doing this, it is able to suppress vibration which is used by the viscosity resistance of liquid. This pressure gauge guarantees its performance and the life span as it has relatively better durability than other general pressure gauges because it prevents abrasion of the interior devices using lubricative fluid.

Safety Management

- Do not give impact during the transportation, installation and usage.
- Be sure to install pressure gauge to be horizontal and vertical.

Purpose of Use

- Oil pressure line
- Places with a lot of vibration, pulsation
- Places where a lot of temperature changes exist
- Compressor, press, etc.

Production Specification

- ▶ Diameter
 - 60, 75, 100 mm
- ▶ Accuracy
 - ±1.5% of Full Scale
- ▶ Working Pressure
 - Static pressure : 75% of Full Scale
 - Fluctuating pressure : 60% of Full Scale
- ▶ Working Temperature
 - Ambient : - 20 ~ 65 °C
 - Fluid : - 20 ~ 80 °C

▶ Range

60mm	- 0.1 ~ 2 MPa
75mm	- 0.1 ~ 0 MPa 0 ~ 35 MPa
100mm	- 0.1 ~ 2 MPa - 0.1 ~ 0 MPa 0 ~ 35 MPa

Product Specification

- | | | |
|------------------------------------------------------------------------------------------------------------------------------------------------------------------------------------------------------------------------------------------------------------------------------------------------------------------------------------------------------------------------------------------------------------------------------------------------------------------------------------------------------------------------------------------------------------------------------------------------------------------|--------------------------------------------------------------------------------------------------------------------------------------------------------------------------------------------------------------------------------------------------------------------------------------------------------------------------------------------------------------------------------------------------------------------------------------------------------------------------------------------------------------------------------------------------------------------------------------------------------------------------------|-----------------------------------------------------------------------------------------------------------------------------------------------------------------------------------------------------------------------------------------------------------------------------------------------------------------------------------------------------------------------------------------------------------------------------------------------------------------------------------------------------------------------------------------------------------------------------------------------------------------------------------------------|
| <ul style="list-style-type: none"> + Case <ul style="list-style-type: none"> · STS 304 + Cover <ul style="list-style-type: none"> · STS 304 · Press Corking + Connection <ul style="list-style-type: none"> · Brass(C3604BE) → Cr-Plating · PF, PT ↔ 3/8, 1/2 + Window <ul style="list-style-type: none"> · Tempered safety glass, · Laminated safety glass | <ul style="list-style-type: none"> + Type <ul style="list-style-type: none"> · A-Type (Rimless type) · B-Type (Surface type) · D-Type (Flush mounting type) · BD-Type (Panel attachment type) + Pointer <ul style="list-style-type: none"> · Aluminum · Black coating + Dial <ul style="list-style-type: none"> · Aluminum · White color coating · Black (MPa), red (bar) gradations and characters | <ul style="list-style-type: none"> + Filling Liquid <ul style="list-style-type: none"> · Silicone oil or Glycerin oil + Element <ul style="list-style-type: none"> · Brass(C2700T) · C type bourdon tube, helical type bourdon tube + Movement <ul style="list-style-type: none"> · Brass + Option <ul style="list-style-type: none"> · Bracket(SS-3077, 3078) · Throttles · Accessories |
|------------------------------------------------------------------------------------------------------------------------------------------------------------------------------------------------------------------------------------------------------------------------------------------------------------------------------------------------------------------------------------------------------------------------------------------------------------------------------------------------------------------------------------------------------------------------------------------------------------------|--------------------------------------------------------------------------------------------------------------------------------------------------------------------------------------------------------------------------------------------------------------------------------------------------------------------------------------------------------------------------------------------------------------------------------------------------------------------------------------------------------------------------------------------------------------------------------------------------------------------------------|-----------------------------------------------------------------------------------------------------------------------------------------------------------------------------------------------------------------------------------------------------------------------------------------------------------------------------------------------------------------------------------------------------------------------------------------------------------------------------------------------------------------------------------------------------------------------------------------------------------------------------------------------|

Pressure Gauge

Differential Pressure Gauge & Switch

Accessories of Pressure Gauge

Thermometer & Thermometer Switch

Thermocouple & RTD

Thermowell

Transmitter

Indicator etc.

Technical data

Liquid Filled Pressure Gauge

Model No. **SS-3075/8 Series**

Model No. | **SS-3075**
A Type (60, 75, 100mm)

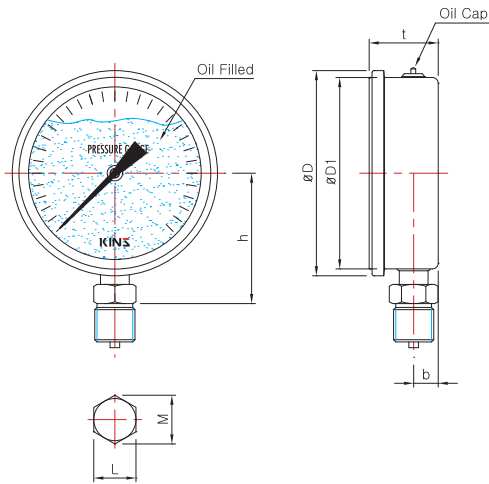

Model No. | **SS-3077**
D Type (60, 75, 100mm)

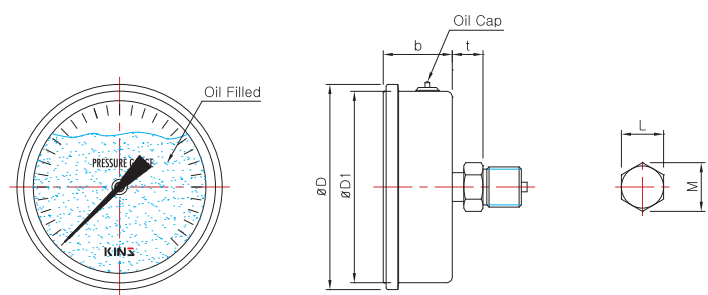

Model No. | **SS-3076**
B Type (60, 75, 100mm)

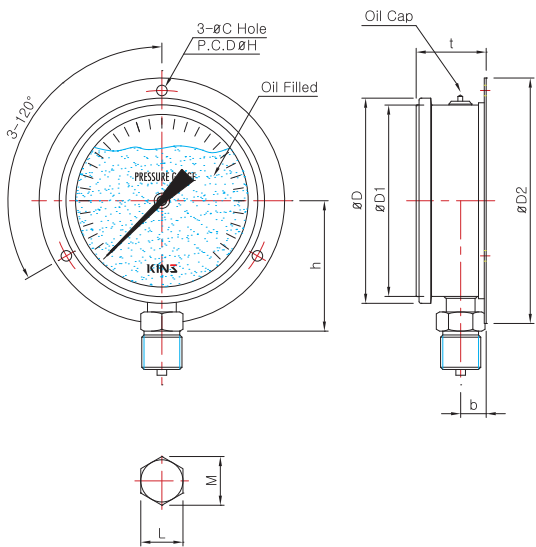

Model No. | **SS-3078**
BD Type (60, 75, 100mm)

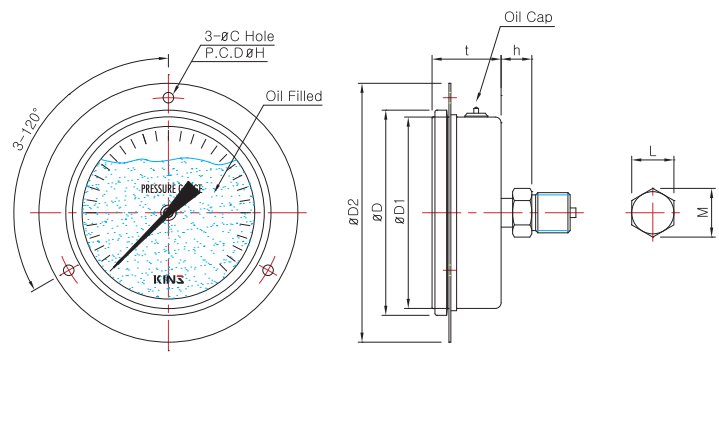

Pressure Gauge

Differential Pressure Gauge & Switch

Accessories of Pressure Gauge

Thermometer & Thermometer Switch

Thermocouple & R.T.D

Thermowell

Transmitter

Indicator etc.

Technical data

Dimensions (mm)

	Model No.	Conn'n (d)	ØD	ØD1	ØD2	b	n	t	L	M	h	ØC	ØH
60mm	SS-3075 & SS-3076	NPT & PT, PF 1/4	72	63	84	10	-	(34)	15	(17,3)	(46)	4,5	72
	SS-3077 & SS-3078	NPT & PT, PF 1/4	72	63	90	-	-	(34)	15	(17,3)	(13)	4,5	81
75mm	SS-3075 & SS-3076	NPT & PT, PF 3/8	86	77	100	14	-	(36)	17	(19,6)	(57)	4,5	88
	SS-3077 & SS-3078	NPT & PT, PF 3/8	86	77	107	-	-	(36)	17	(19,6)	(16)	4,5	97
100mm	SS-3075 & SS-3076	NPT & PT, PF 3/8	107	100	128	14	-	(46)	17	(19,6)	(68)	5,5	115
		NPT & PT, PF 1/2						22	(25,4)				
	SS-3077 & SS-3078	NPT & PT, PF 3/8	107	100	135	-	-	(46)	17	(19,6)	(16)	5,5	120
		NPT & PT, PF 1/2						22	(25,4)				

*()The measurement in the blanket is approximate.

Pressure Gauge

Differential Pressure Gauge & Switch

Accessories of Pressure Gauge

Thermometer & Thermometer Switch

Thermocouple & R.T.D

Thermowell

Transmitter

Indicator etc.

Technical data