



## PA Series

### Variable Area Flowmeter

- 전원 장치 없이 사용하는 현장 지시 유량계
- 작은 공간에 적합하도록 디자인 되어 일반 공장 배관 라인 및 판넬 등 쉽게 취부 가능
- 유체의 순간 흐름 쉽게 확인 가능 (거품, 색상 등)

## PA-80 Series General Specifications

Size	15A (1/2") ~ 25A (1")
Process Connection	NPT
Measuring Fluid	Gas and Liquid
Accuracy	±4.0 % F.S
Fluid Temperature	Max. 70 °C
Max. Pressure	Max. 6 kgf/cm <sup>2</sup> .G

### MODEL CODE

PA-80	-	□	-	□	Specification
		2 ~ 7			Flow ranges 참조 Bottom side to Top side
				V	Valve

### STRUCTURAL DRAWING

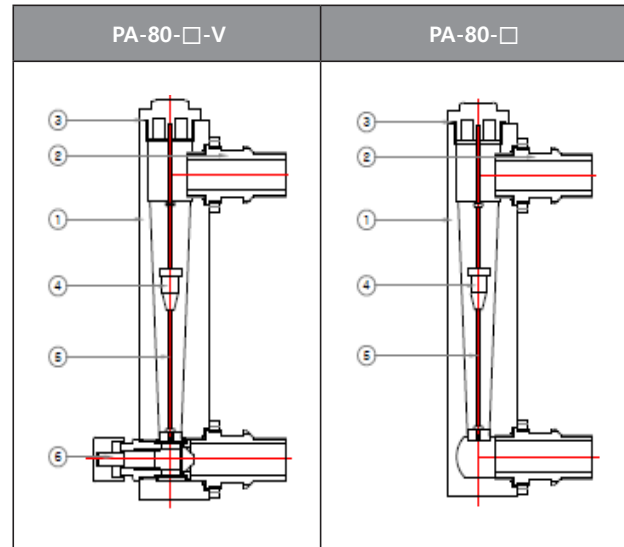

### STANDARD MATERIAL

No.	Description	Material
1	Body	Machined acrylic
2	Adapter	Polypropylene
3	O-ring	Viton
4	Float	SUS316
5	Guide bar	SUS316

### FLOW RANGES & DIMENSIONS



Model	Size ( mm )						Measure Range		Coonection
	A	B	C	D	E	F	GPM	LPM	
PA-80-2	215	34	40	31	20	165	0.2 - 2	1 - 7	1/2" NPT
PA-80-3							0.5 - 5	1.8 - 18	
PA-80-4	233	41	45	47	33	165	2 - 10	8 - 40	3/4" NPT
PA-80-5							2 - 16	6 - 60	
PA-80-6	254	45	50	47	33	175	4 - 24	20 - 100	1" NPT
PA-80-7							5 - 35	30 - 130	