



GA Series

Variable Area Flowmeter

- 전원 장치 없이 사용하는 현장 지시 유량계
- 전단 or 후단에 벨브 설치 가능 / 알람 기능 선택적으로 제공
- 유체의 순간 흐름 쉽게 확인 가능 (거품, 색상 등)

GA-70 Series General Specifications

Size	15A(1/2") ~ 65A(2-1/2")
Process Connection	KS/JIS/ASME/DIN Std. Flange
Flow Ranges	Water - 0.03 m ³ /h ~ 30 m ³ /h Air - 0.3 Nm ³ /h ~ 400 Nm ³ /h
Range Ability	10 : 1
Accuracy	±2.0 % F.S
Fluid Temperature	Max 120 °C
Max. Pressure	Max. 10 kgf/cm ² .G

STRUCTURAL DRAWING

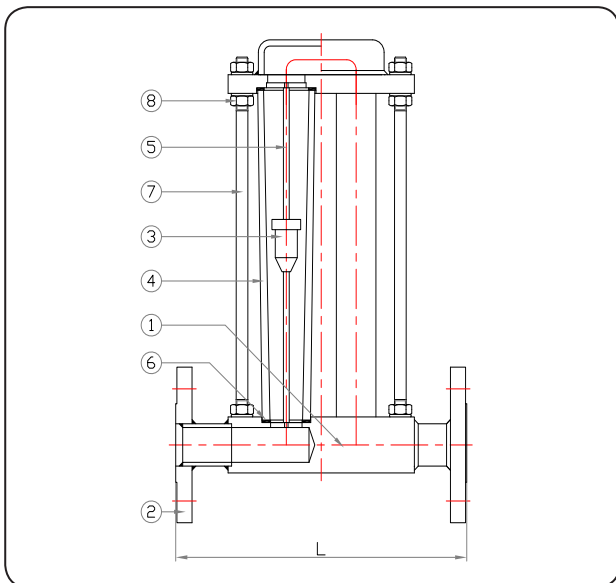

STANDARD MATERIAL

No.	Description	Material				
		A	B	C	D	E
1	Body	SS400	304SS	316SS	316LSS	PVC
2	Flange					
3	Float	304SS/316L, PVC, ACETAL, PTFE				
4	Taper tube	PYREX GLASS, PC				
5	Guide bar	304SS		316LSS, PTFE LINER		
6	Packing	NBR, EPDM, SILICON, FKM, PTFE				
7	Post	SS400	304SS			
8	Nut					

FLOW RANGE & DIMENSIONS

Size	Float	Water (m ³ /h)		Air (Nm ³ /h)	
		304SS	PVC	Ebonite PVC, PTFE	ALUMINUM 304SS
15A		0.03 - 0.3	0.05 - 0.5	0.3 - 3	0.3 - 3
		0.2 - 2	0.15 - 1.5	1.2 - 12	2 - 20
20A		0.03 - 0.3	0.05 - 0.5	0.3 - 3	0.3 - 3
		0.2 - 2	0.15 - 1.5	2 - 20	3 - 30
25A		0.15 - 1.5	0.1 - 1	1 - 10	1.5 - 15
		0.5 - 5	0.35 - 3.5	4 - 40	6 - 60
32A		0.3 - 3	0.2 - 2	2 - 20	3 - 30
		0.7 - 7	0.5 - 5	7 - 70	10 - 100
40A		0.35 - 3.5	0.3 - 3	3 - 30	4.5 - 45
		1.2 - 12	1 - 10	12 - 120	15 - 150
50A		1 - 10	0.8 - 8	3.5 - 35	5 - 50
		2 - 20	1.5 - 15	15 - 150	20 - 200
65A		1.5 - 15	1.2 - 12	6 - 60	9-90
		3 - 30	2.5 - 25	30 - 300	40 - 400