



GA Series

Variable Area Flowmeter

- 전원 장치 없이 사용하는 현장 지시 유량계
- 전단 or 후단에 밸브 설치 가능 / 알람 기능 선택적으로 제공
- 유체의 순간 흐름 쉽게 확인 가능 (거품, 색상 등)

GA-60 Series General Specifications

Size	10A(0.5S) ~ 50A(2-1/2S)
Process Connection	IDE Clamp / Male
Flow Ranges	(0 ~ 25,000) L/h
Range Ability	10 : 1
Accuracy	±2.0 % F.S (Option ±1.0 % F.S)
Fluid Temperature	Max 120 °C
Max. Pressure	Max. 10 kgf/cm ² .G

STRUCTURAL DRAWING

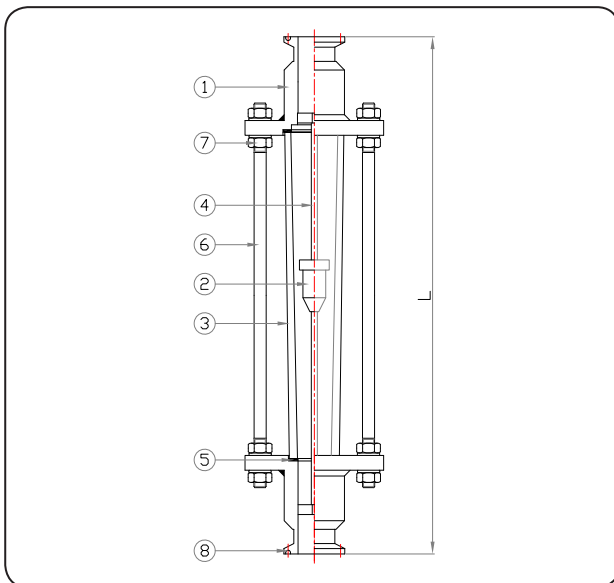

STANDARD MATERIAL

No.	Description	Material		
		A	B	C
1	Body	SS400	304SS	316SS
2	Float			
3	Taper tube	PYREX GLASS		
4	Guide bar	304SS	316SS	316LSS
5	Packing	NBR, EPDM, SILICON, FKM, PTFE		
6	Post	304SS		
7	Nut			
8	Clamp	304SS	316SS	316LSS

FLOW RANGE & DIMENSIONS

Meter Size	Con'n. size	L (mm)	Flow rate (L/h)
10A	0.5S	360	min. 0 - 50 / max. 0 - 500
15A	1S	360	max. 0 - 1000
20A	1S	360	max. 0 - 2000
25A	1S ~ 1-1/2S	420	max. 0 - 3500
40A-①	1S ~ 2S	440	max. 0 - 8000
40A-②	1-1/2S ~ 2S	440	max. 0 - 10000
50A	2S ~ 2-1/2S	480	max. 0 - 25000