



DAT Series

Differential Pressure Flow meter
with Pipe Thread Type Connection

FEATURE

- 기체와 액체 모드 사용 가능
- 설치 및 보수가 간단
- 배관 내 탈부착이 용이
- 유체의 방향 제한이 없음
- 설치 비용이 저렴

APPLICATIONS

- ▶ 화학과 기타 공정 산업
- 산, 염기, 인산염과 기타 염화물, 황산 물질
- 응축수 과 냉각수
- ▶ 정유 및 가스 산업
- 질소, 연도 가스 등
- ▶ 기계 및 장비(OEM산업)
- 냉각재, 냉각수, 윤활유, 공기 공급
- ▶ 수자원 산업

DAT Series General Specifications

Size	10A (3/8") - 80A (3")
Process Connection	Screw (Male or Female)
Measured Fluid	Gas and Liquid
Flow Ranges	Water - 0.08 m ³ /h ~ 42 m ³ /h Air - 0.8 Nm ³ /h ~ 400 Nm ³ /h
Range Ability	5 : 1
Accuracy	±2.0 % F.S (Option ±1.0 % F.S)
Fluid Temperature	Max 120 °C
Allowable Thermal Shock	Max 80 °C
Max. Pressure	Max. 10 kgf/cm ² .G

MODEL CODE

D	A	T	-	□	Specification
				A	Alarm Switch
				C	Connector
				V	By pass Valve

STANDARD MATERIAL

No.	Description	Material		
		A	B	C
1	Body	SS400	304SS	316SS
2	Base socket	BRASS	304SS	316SS
3	Strainer	304SS		316SS
4	Orifice			
5	Packing	NBR, EPDM, SILICON, FKM		
6	Taper tube	PYREX GLASS		
7	Float	304SS, AGATE		316SS
8	Indicator	304SS		316SS

STRUCTURAL DRAWING

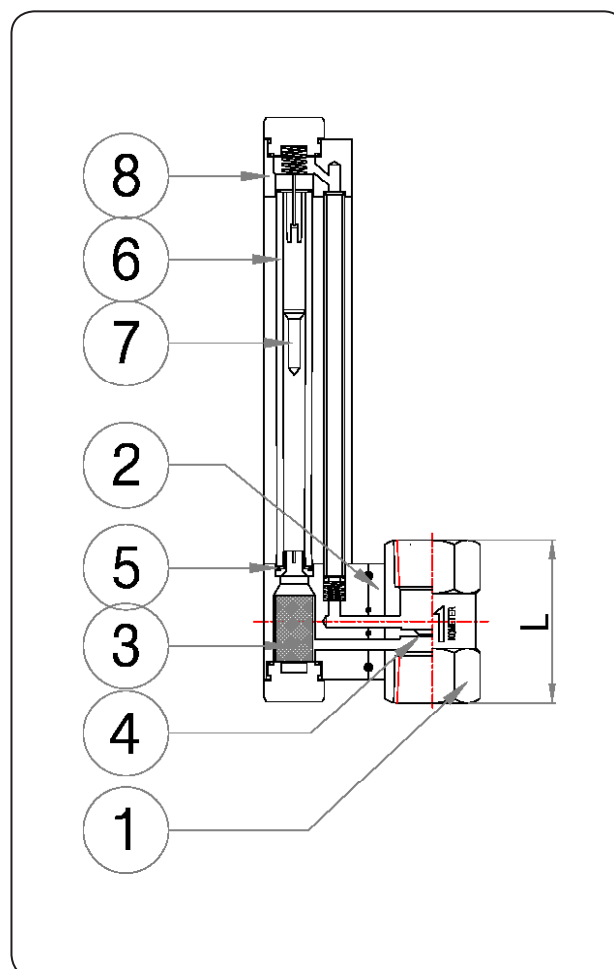

FLOW RANGE & DIMENSIONS

Connection size		Water (m ³ /h)		Air (Nm ³ /h)		Length (L, mm)
		유량범위	분해능	유량범위	분해능	
10A	3/8 B	0.08 - 0.45	0.02	0.8 - 4	0.1	70
15A	1/2 B	0.2 - 1.2	0.02	2 - 9.2	0.2	70
20A	3/4 B	0.45 - 2.4	0.05	5 - 23	0.5	70
25A	1 B	0.9 - 4.8	0.1	8 - 40	1	70
32A	1-1/4 B	1.4 - 7.2	0.2	12 - 60	2	70
40A	1-1/2 B	2 - 12	0.2	18 - 90	2	74
50A	2 B	3.5 - 18.5	0.5	35 - 175	5	85
65A	2-1/2 B	6 - 32	1	60 - 300	10	100
80A	3 B	8 - 42	1	80 - 400	10	100

ALARM OUTPUT UNIT (REED SWITCH TYPE)

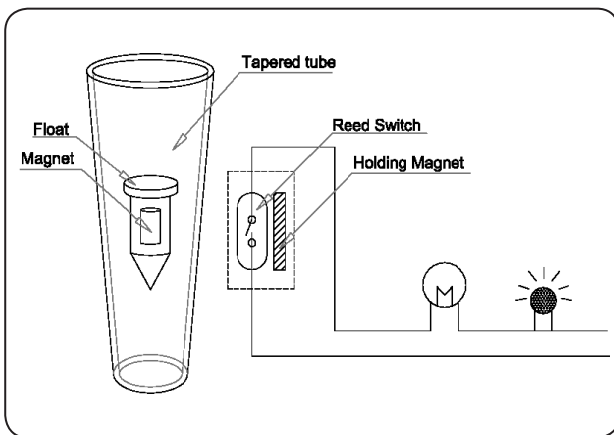

Contact Reed switch	Self holding type
Max. Contact capacity	AC 10 VA DC 10 W
Max. Voltage	AC 125 V DC 100 V
Max. Temperature	-10 °C ~ 60 °C
Cable length	1 m