



SG-10 Series

Sight Glass

- 현장 조건에 맞게 End Connection 선택 가능
- 투명 글라스를 통하여 유체의 색조 및 기포의 혼입상태 등을 관측
- 다양한 재질 선택으로 사용 유체 범위 넓음

SG-101 General Specifications

Size	8A(1/4") ~ 50A(2")
Process Connection	PT
Fluid Temperature	Max. 150 °C (Option 200 °C)
Max. Pressure	Max. 10 kgf/cm ² .G (Option 50 kgf/cm ² .G)

STANDARD MATERIAL

No.	Description	Material
1	Window	HARD GLASS
2	Body	SS400, 304SS, 316SS
3	Packing	NBR, PTFE
4	Cover	Aluminum

DIMENSIONS

Connection Size		L (mm)	H (mm)
8A	1/4B	70	55
10A	3/8 B	70	55
15A	1/2 B	80	60
20A	3/4 B	90	70
25A	1 B	135	92
32A	1-1/4 B	165	130
40A	1-1/2 B	165	130
50A	2 B	180	140

STRUCTURAL DRAWING

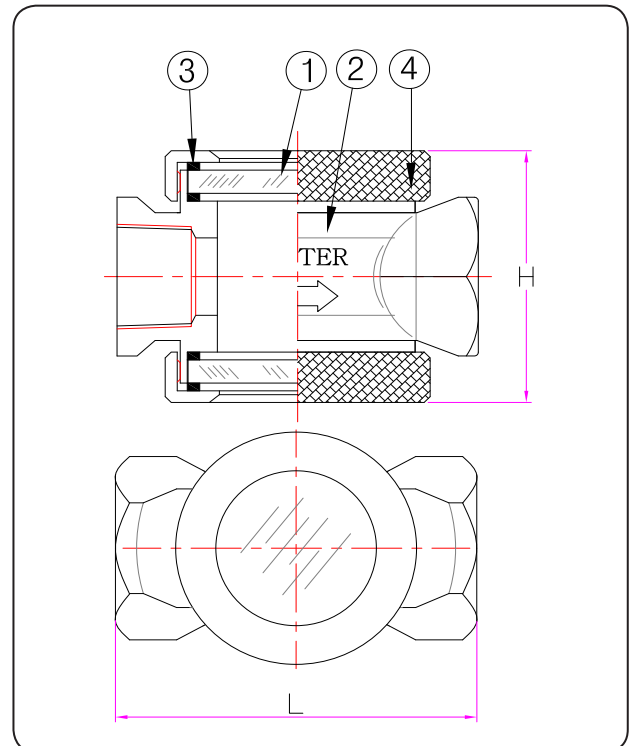

SG-102 General Specifications

Size	10A(3/8") ~ 200A(8")
Process Connection	KS/JIS/ASME/DIN Std. Flange
Fluid Temperature	Max. 150 °C (Option 200 °C)
Max. Pressure	Max. 10 kgf/cm ² .G (Option 30 kgf/cm ² .G)

STANDARD MATERIAL

No.	Description	Material
1	Window	HARD GLASS
2	Body	SS400, 304SS, 316SS
3	Bolt	SS400, 304SS
4	Cover	SS400, 304SS, 316SS
5	Flange	SS400, 304SS, 316SS

DIMENSIONS

Connection Size		L (mm)	H (mm)
10A	3/8 B	160	80
15A	1/2 B	160	80
20A	3/4 B	180	100
25A	1 B	180	102
32A	1-1/4 B	180	140
40A	1-1/2 B	180	140
50A	2 B	220	150
65A	2-1/2 B	270	200
80A	3 B	270	200
100A	4 B	320	228
125A	5 B	380	270
150A	6 B	420	300
200A	8 B	490	430

STRUCTURAL DRAWING

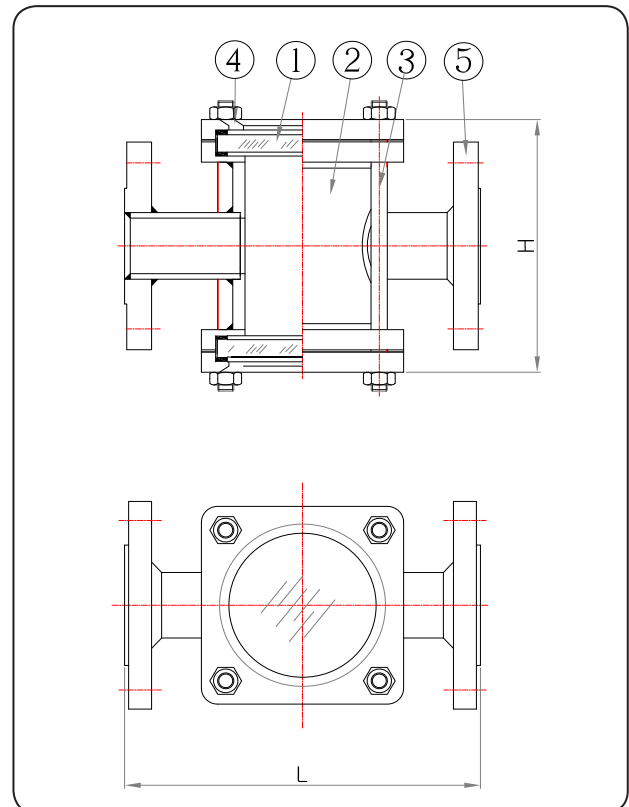

SG-103 General Specifications

Size	10A(3/8") ~ 200A(8")
Process Connection	KS/JIS/ASME/DIN Std. Flange
Fluid Temperature	Max. 150 °C (Option 200 °C)
Max. Pressure	Max. 10 kgf/cm ² .G (Option 30 kgf/cm ² .G)

STANDARD MATERIAL

No.	Description	Material		
		A	B	C
1	Flange	SS400	304SS	316SS
2	Nut	SS400	304SS	
3	Tube	HARD GLASS, ACRYL		
4	Packing	NBR, PTFE		
5	Post	SS400	304SS	

DIMENSIONS

Connection Size		L (mm)
15A	1/2 B	150
20A	3/4 B	150
25A	1 B	180
32A	1-1/4 B	180
40A	1-1/2 B	180
50A	2 B	200
65A	2-1/2 B	200
80A	3 B	200
100A	4 B	230
125A	5 B	230
150A	6 B	240
200A	8 B	250

STRUCTURAL DRAWING

