



## PA Series

### Variable Area Flowmeter

- 전원 장치 없이 사용하는 현장 지시 유량계
- 작은 공간에 적합하도록 디자인 되어 일반 공장 배관 라인 및 패널 등 쉽게 취부 가능
- 유체의 순간 흐름 쉽게 확인 가능 (거품, 색상 등)

## PA-10 Series General Specifications

Size	1/2" ~ 3/4"
Process Connection	PT, NPT (Female)
Flow Ranges	Water - 10 L/h ~ 2,500 L/h Air - 250 NL/h ~ 30,000 NL/h
Range Ability	10 : 1
Accuracy	±2.0 % F.S (Option ±1.0 % F.S)
Fluid Temperature	Max. 120 °C
Max. Pressure	Max. 10 kgf/cm <sup>2</sup> .G

## MODEL CODE

PA-10	-	<input type="checkbox"/>	Specification
	A		Alarm switch

## STANDARD MATERIAL

No.	Description	Material		
		A	B	C
1	Body	304SS	316SS	PVC
2	Float	304SS PTFE PVC	316SS PTFE	PVC
3	Taper tube	PYREX GLASS		
4	Needle Valve	304SS	316SS	PVC
5	Packing	NBR, PTFE, FPM		EPDM
6	Cover	ACRYL		
7	Mounting Nut	BRASS		
8	Guide bar	304SS	316SS	PTFE LINER

## STRUCTURAL DRAWING

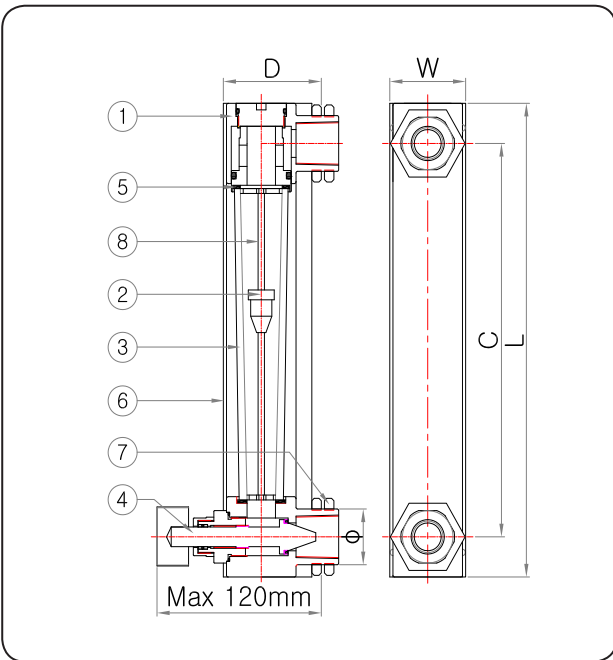

## DIMENSIONS

치수 (mm)				
L	C	W	D	Ø
290	240	50	49	34

## FLOW RANGES

표준사양		특수사양	
Water (L/h)	Air (NL/h)	Water (L/h)	Air (NL/h)
16 - 160	400 - 4000	10 - 100	250 - 2500
20 - 250	600 - 6000		
40 - 400	1000 - 10000	250 - 2500	3000 - 30000
100 - 1000	1600 - 16000		