

Direct reading thermometer

Model : T220

Spec. sheet no. TD02-05

Service intended



Nominal diameter

100 and 150 mm

Accuracy

±2.0% of full scale

Measuring system (SAMA class IIIB)

Organic gas : 0 ~ 200°C

Inert gas : -200 ~ 700°C

Working range

Maximum scale value



Standard features

Location of stem

Bottom connection, direct
Lower back connection, direct

Case

304SS

Cover

304SS

Window

Tempered safety glass

Dial

White aluminium with black graduation

Pointer

304SS, Black painted

Stem

8.0, 10.0 and 12.0 mm
316SS and 316L SS

Zero adjustment

Internal

Stem, process connection

3/8", 1/2", 3/4" PT, NPT and PF

Option

±1.0% of full scale

1. Base model**T220** Direct reading thermometer**2. Nominal diameter (mm)**

- 4** 100
6 150

3. Type of mounting

- A** Bottom connection, direct
G Lower back connection, direct

4. Stem material

- 1** 316SS
2 316L SS

5. Stem, process connection

- A** None
D 3/8"
E 1/2"
F 3/4"

6. Stem connection type (CF: Compression fitting)

- A** None
E CF + PT
F CF + NPT
G CF + PF
H MT + PT (Movable thread)
I MT + NPT (Movable thread)
J MT + PF (Movable thread)

7. Stem outer diameter (mm)

- 2** 8.0
3 10.0
4 12.0
Z Other

8. Range**XXX** Refer to scale range table**9. Insertion length****X** Refer to insertion length table**10. Accessories**

- 0** None
1 Thermowell
2 Special accuracy ($\pm 1.0\%$ of full scale)
3 Thermowell and special accuracy

1	2	3	4	5	6	7	8	9	10
T220	4	A	1	E	C	3	XXX	X	1

Sample
ordering code

T220 : Type of mounting

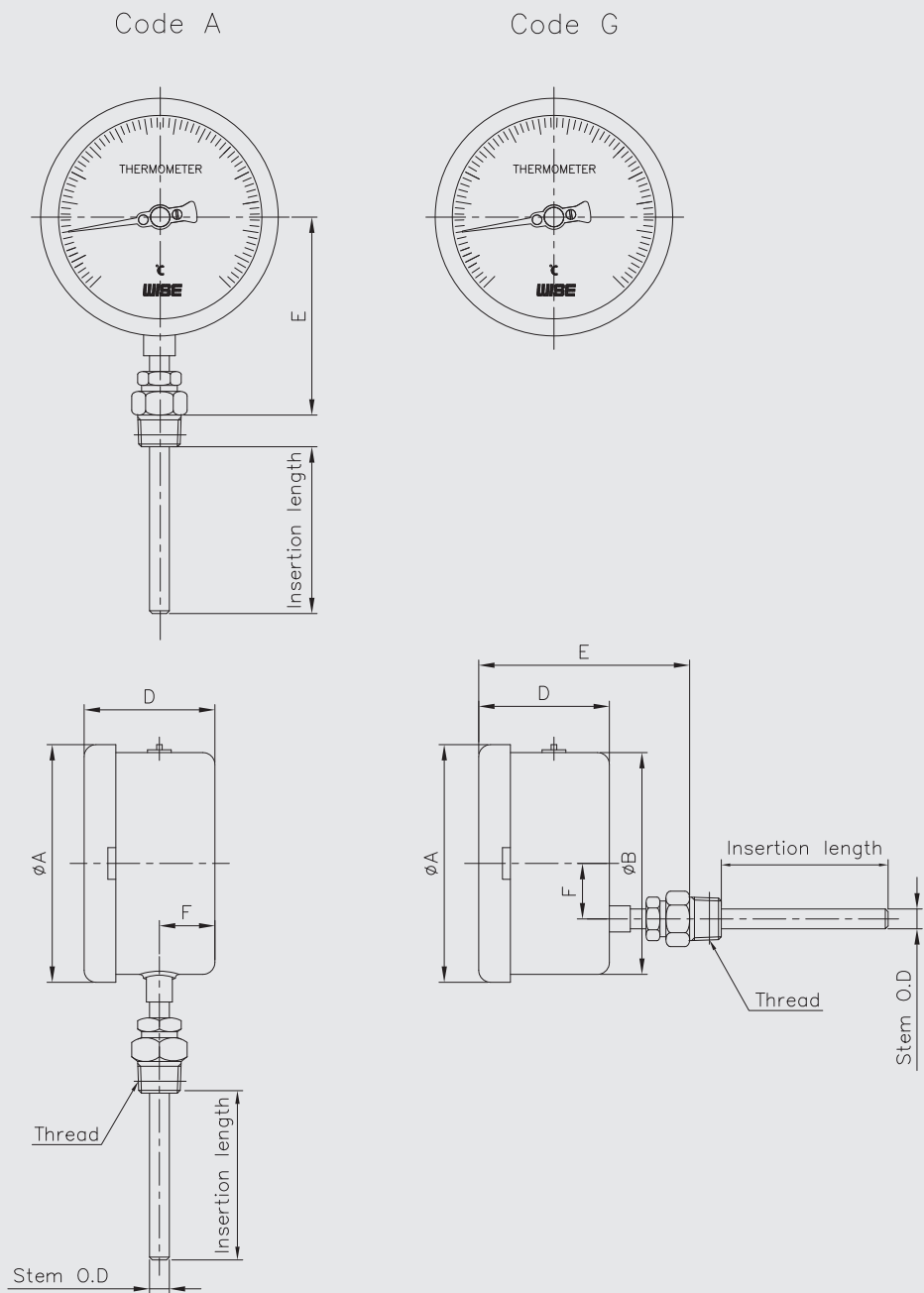

Dimensions (mm)

Dial Size	Available code	A	B	$D \pm 2$	$E \pm 2$	$F \pm 1$
100	A	111		48.5	100	17
	G	111	99.5	48.5	98.5	30
150	A	168.5		63	125	22
	G	168.5	153	63	113	55

Scale ranges

Code	Scale range (°C)	Scale spacing (°C)	Minimum stem length (mm)		
			8.0	10.0	12.0
031	-200 ~ 100	5	500	500	500
032	-50 ~ 50	2	100	85	65
037	-50 ~ 100	2	100	85	65
054	-30 ~ 50	2	100	88	65
059	-30 ~ 100	5	100	85	65
061	-30 ~ 120	2	100	85	65
069	-20 ~ 50	2	100	85	65
074	-20 ~ 100	2	100	85	65
079	-20 ~ 150	5	100	85	65
084	-10 ~ 50	1	100	85	65
099	0 ~ 50	1	100	85	65
100	0 ~ 60	1	100	85	65
101	0 ~ 70	2	100	85	65
102	0 ~ 80	1	100	85	65
104	0 ~ 100	2	100	85	65
106	0 ~ 120	2	100	85	65
109	0 ~ 150	2	100	85	65
114	0 ~ 200	5	100	85	65
119	0 ~ 250	5	100	85	65
124	0 ~ 300	5	100	85	65
129	0 ~ 350	5	100	85	65
134	0 ~ 400	5	100	85	65
144	0 ~ 500	10	100	85	65
154	0 ~ 600	10	100	85	65
164	0 ~ 700	10	100	85	65

* 0 ~ 700°C/Special range

* -200 ~ 100°C/Special range

Insertion length

Code	1	2	3	4	5	6	7	8	9	A	B	C
Length (mm)	50	60	70	80	100	120	130	150	175	200	225	250

Code	D	E	F	G	H	J	K	L	M	N	P
Length (mm)	275	300	350	375	400	450	500	550	1,000	1,500	2,000