

Direct reading thermometer with adjustable stem

Model : T290

Spec. sheet no. TD02-14

Service intended



577

Nominal diameter

100 and 150 mm

Accuracy

±2.0% of full scale

Measuring system (SAMA class IIIB)

Organic gas : 0 ~ 200°C

Inert gas : -200 ~ 700°C

Working range

Maximum scale value



Standard features

Location of stem

Lower back with adjustable stem

Pointer

Black painted aluminium alloy

Case

304SS, Adjustable on stem 90°

Stem

8.0, 10.0 and 12.0 mm
316SS and 316L SS

Cover

304SS

Zero adjustment

Internal

Window

Tempered safety glass

Stem, process connection

3/8", 1/2", 3/4" PT, NPT and PF

Dial

White aluminium with black graduation

Stem connection type

Movable thread

Option

±1.0% of full scale

DAEQIN

TEL : 02 - 2631 - 7290

198 17 131 (가 C)

FAX : 02 - 2675 - 0605

<http://www.gauge.co.kr>

e-mail : dajinbs@hanmail.net

1. Base model

T290 Direct reading thermometer with adjustable stem

2. Nominal diameter (mm)

4 100
6 150

3. Type of mounting

Y Lower back with adjustable stem

4. Stem material

1 316SS
2 316L SS

5. Stem, process connection

A None
D $\frac{3}{8}$ "
E $\frac{1}{2}$ "
F $\frac{3}{4}$ "

6. Stem connection type (CF: Compression fitting)

A None
E CF + PT
F CF + NPT
G CF + PF
H MT + PT (Movable thread)
I MT + NPT (Movable thread)
J MT + PF (Movable thread)

7. Stem outer diameter (mm)

2 8.0
3 10.0
4 12.0
Z Other

8. Range

XXX Refer to scale range table

9. Insertion length

X Refer to insertion length table

10. Accessories

0 None
1 Thermowell
S Special accuracy ($\pm 1.0\%$ of full scale)
T Thermowell and special accuracy

1	2	3	4	5	6	7	8	9	10
T290	4	Y	1	E	C	3	XXX	X	1

Sample
ordering code

T290 : Type of mounting

Code Y

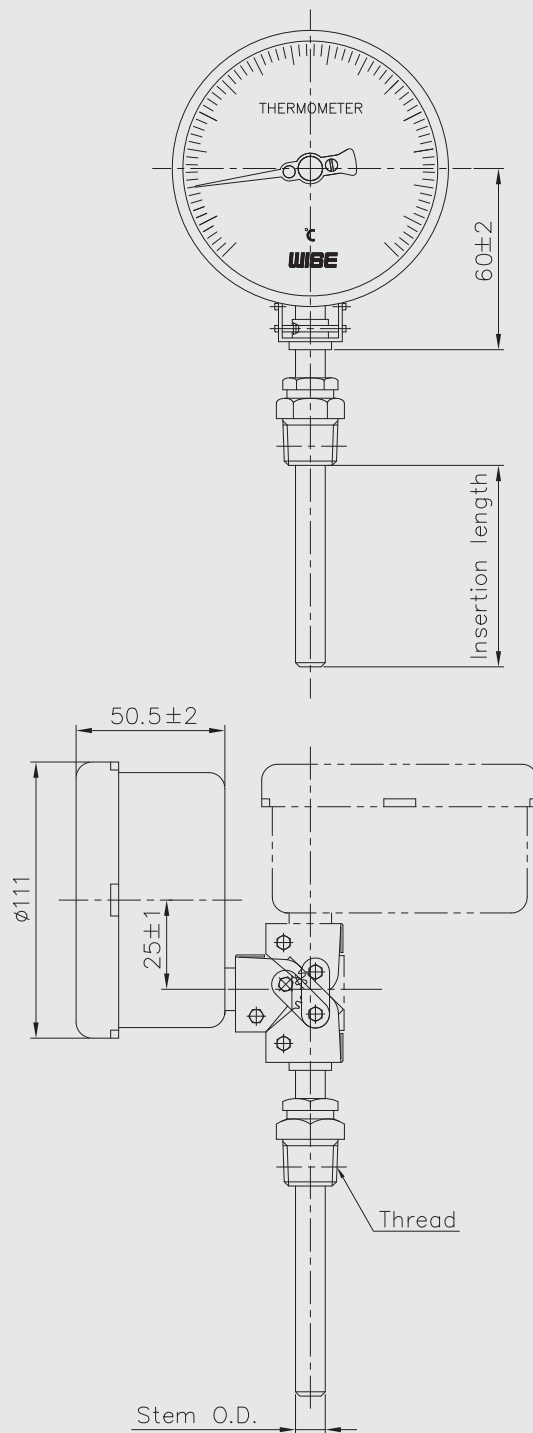

Scale ranges

Code	Scale range (°C)	Scale spacing (°C)	Minimum stem length (mm)		
			8.0	10.0	12.0
031	-200 ~ 100	5	500	500	500
032	-50 ~ 50	2	100	85	65
037	-50 ~ 100	5	100	85	65
054	-30 ~ 50	2	100	88	65
059	-30 ~ 100	5	100	85	65
061	-30 ~ 120	2	100	85	65
069	-20 ~ 50	2	100	85	65
074	-20 ~ 100	2	100	85	65
079	-20 ~ 150	5	100	85	65
084	-10 ~ 50	1	100	85	65
099	0 ~ 50	1	100	85	65
100	0 ~ 60	1	100	85	65
101	0 ~ 70	2	100	85	65
102	0 ~ 80	1	100	85	65
104	0 ~ 100	2	100	85	65
106	0 ~ 120	2	100	85	65
109	0 ~ 150	2	100	85	65
114	0 ~ 200	5	100	85	65
119	0 ~ 250	5	100	85	65
124	0 ~ 300	5	100	85	65
129	0 ~ 350	5	100	85	65
134	0 ~ 400	5	100	85	65
144	0 ~ 500	10	100	85	65
154	0 ~ 600	10	100	85	65
164	0 ~ 700	10	100	85	65

* 0 ~ 700°C/Special range

* -200 ~ 100°C/Special range

Insertion length

Code	1	2	3	4	5	6	7	8	9	A	B	C
Length (mm)	50	60	70	80	100	120	130	150	175	200	225	250

Code	D	E	F	G	H	J	K	L	M	N	P
Length (mm)	275	300	350	375	400	450	500	550	1,000	1,500	2,000