

Process industry bimetal thermometer with adjustable stem

Model : T190

Spec. sheet no. TD01-09

Service intended

가



가

Nominal diameter

75, 100, 125 and 150 mm

Accuracy

±2.0% of full scale

Temperature element

Coiled bimetal

Working range

Maximum scale value



Standard features

Location of stem

Center back with adjustable stem

Pointer

Black painted aluminium alloy

Case

304SS, Adjustable on stem 90°

Stem

6.0, 6.4, 8.0 and 10.0 mm diameter
304SS, 316SS and 316L SS
Max. Insertion length : 2,000 mm

Cover

304SS

Zero adjustment

External

Window

Glass

Stem, process connection

1/4", 3/8", 1/2", 3/4" PT, NPT and PF

Dial

White aluminium with black graduations

Option

±1.0% of full scale
Window : Safety glass
Special range : 0 ~ 600°C

DAEJIN

TEL : 02 - 2631 - 7290

<http://www.gauge.co.kr>

e-mail : dajinbs@hanmail.net

198 17 131 ()

가 C)

1. Base model

T190 Process industry bimetal thermometer with adjustable stem

2. Nominal diameter (mm)

- 3 75
- 4 100
- 5 125
- 6 150

3. Type of mounting

- Y Center back with adjustable stem

4. Stem material

- 0 304SS
- 1 316SS
- 2 316L SS

5. Stem, process connection

- A None
- C ¼"
- D ⅜"
- E ½"
- F ¾"
- G 1½S (Only available with sanitary)
- H 2S (Only available with sanitary)
- I 2½S (Only available with sanitary)

6. Stem connection type (CF: Compression fitting)

- A None
- B PF
- C PT
- D NPT
- E CF + PT
- F CF + NPT
- G CF + PF
- H MT + PT (Movable thread)
- I MT + NPT (Movable thread)
- J MT + PF (Movable thread)
- S Clamp (Sanitary type flange)

7. Stem outer diameter (mm)

- 0 6.0
- 1 6.4
- 2 8.0
- 3 10.0 (Not available process connection, ¼")

8. Range

XXX Refer to scale range table

9. Insertion length

X Refer to insertion length table

10. Accessories

- 0 None
- 1 Thermowell
- 2 Special accuracy (±1.0% of full scale)
- 3 Thermowell and special accuracy

1	2	3	4	5	6	7	8	9	10
T190	4	Y	0	E	C	1	XXX	X	1

Sample
ordering code

T190 : Type of mounting

Code Y

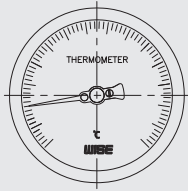

Code Y*

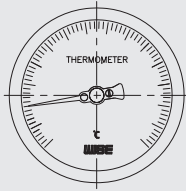

Code Y**

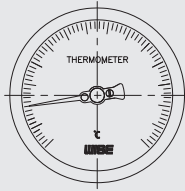

Code Y***

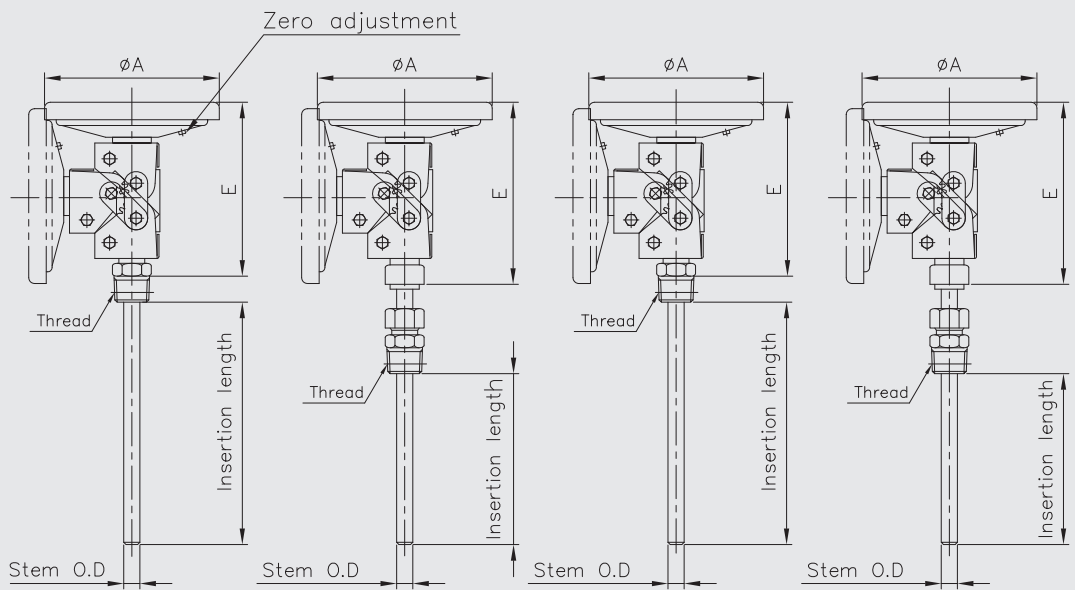
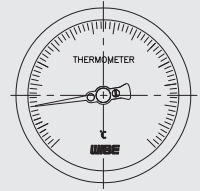

Dimensions (mm)

Dial Size	Available code	A	E±2
75	Y	86.5	101
	Y*	86.5	99
100	Y	111	105
	Y*	111	103
125	Y	137.5	103
	Y*	137.5	101
150	Y**	169.5	132
	Y***	169.5	130

Scale ranges

Code	Scale range (°C)	Scale spacing (°C)	Minimum stem length (mm)	
			6.0 and 6.4	8.0 and 10.0
032	-50 ~ 50	2	55	50
037	-50 ~ 100	2	45	35
054	-30 ~ 50	2	70	60
059	-30 ~ 100	2	50	45
061	-30 ~ 120	2	45	35
069	-20 ~ 50	2	80	70
074	-20 ~ 100	2	45	45
079	-20 ~ 150	5	40	35
084	-10 ~ 50	1	95	80
099	0 ~ 50	1	110	70
100	0 ~ 60	1	95	80
101	0 ~ 70	2	80	60
102	0 ~ 80	1	70	55
104	0 ~ 100	2	55	50
106	0 ~ 120	2	50	45
109	0 ~ 150	2	45	35
114	0 ~ 200	5	35	35
119	0 ~ 250	5	35	30
124	0 ~ 300	5	35	25
129	0 ~ 350	5	30	25
134	0 ~ 400	5	80	65
144	0 ~ 500	10	70	60
154	0 ~ 600	10	70	60

Insertion length

Code	1	2	3	4	5	6	7	8	9	A	B	C
Length (mm)	50	60	70	80	100	120	130	150	175	200	225	250

Code	D	E	F	G	H	J	K	L	M	N	P
Length (mm)	275	300	350	375	400	450	500	550	1,000	1,500	2,000